

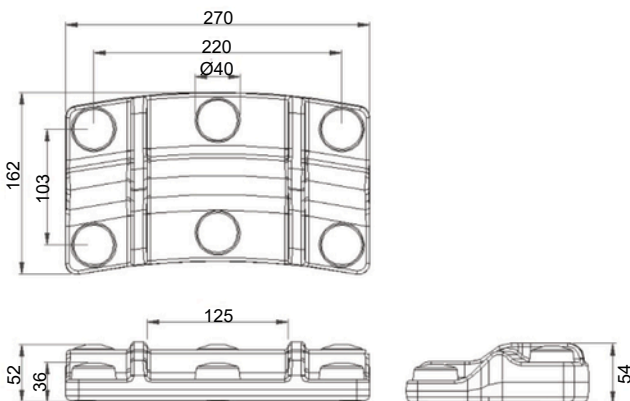

- ▶ **Multi-pedal footswitch, 1-8-pedal version**
- ▶ **Compact for discrete placement beneath equipment or for storage**
- ▶ **Robust and aesthetic design**
- ▶ **Soft touch buttons with a light operating force**
- ▶ **Ideal for motion control applications**

Specifications	
Standards / Approvals	Switches: UL 60601-1, File No. E353500, IEC 60601-1
Degree of protection	EN 60529 IP67 (IP68 upon request)
Connection method	Stripped cable cores or connector of your choice, straight or curly coil cable
Electrical rating	50mA 24V DC
Contact configuration	SPST N/O
Operating temperature	+ 10° C to + 50° C
Body material	Thermoplastic
Weight	1.0 kg
Additional information	Choice of colours, logos and labels available

Dimensions



Australian Distributor

K. D. Fisher & Co. Pty Ltd ABN 27 007 879 647
 Head office 18 Benjamin Street St Marys SA
 5042 T +61 8 8277 3288 T 1300 533 474
 E kdf@kdfisher.com.au kdfisher.com.au