

- ▶ **Lightweight operation over the entire top surface**
- ▶ **Customer logos available upon request**
- ▶ **These switches may be used in multipedal configurations**

Specifications	
Standards/approvals	Low voltage directive 2014/35/EU
Degree of protection	EN 60529 IP67 (IP68 on request)
Connection method	Stripped cable cores or connector of your choice, straight cable
Electrical rating	50mA 24V DC
Contact configuration	SPST N/O
Pressure range	n/a
Operating temperature range	+10° C to +50° C
Body material	Thermoplastic
Weight	0.06Kg (including cable)
Additional information	Only available in red

Dimensions

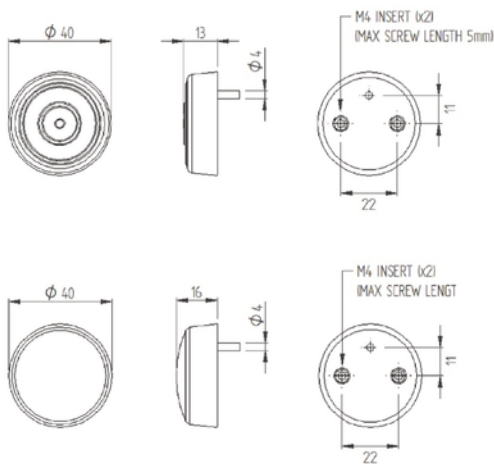

Australian Distributor

K. D. Fisher & Co. Pty Ltd ABN 27 007 879 647
 Head office 18 Benjamin Street St Marys SA
 5042 T +61 8 8277 3288 T 1300 533 474
 E kdf@kdfisher.com.au kdfisher.com.au