



- ▶ Sensitive versatile switch, ideal for long tube lengths
- ▶ Ideal for switching low power circuits
- ▶ Temperature compensated versions available
- ▶ Easily adjustable settings

The 6753 range of switches provide a high specification in a small, versatile body shell. Great care has been taken in the switch unit design keeping the moving mass and therefore inertia to a minimum. This means that it can operate at a high cycle rate with low pressure or vacuum.

When measuring pressure pulses such as on component counting applications, the switch will operate very rapidly due to the low inertia of the moving parts and the low swept volume.

For good repeatable switching, the contacts are gold plated on solid silver. The operating pressure will have a direct effect on the contact pressure; therefore at very low pressures the maximum contact rating will not be achieved.

For a normally open switch the contacts can be closed either by applying pressure at port B or vacuum at port A.

For a normally closed switch, the contacts can be opened either by applying pressure at port A or vacuum at port B.

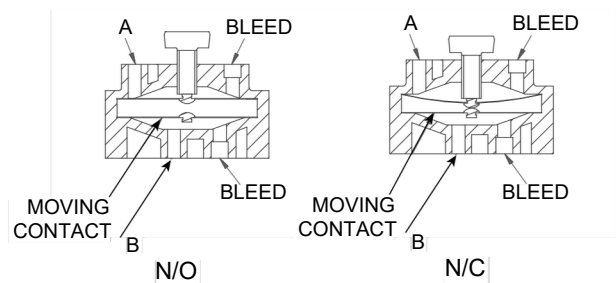

Where temperature compensation is required, consider carefully which side of the moving contact the bleed should be fitted. This will vary dependant on pressure or vacuum operation.



Specifications	
Standards/approvals	UL 508 specific models only
Degree of protection	n/a
Connection method	Via back entry spout, Ø4 mm
Electrical rating	0.5A 250V AC
Contact configuration	SPST, N/O or N/C
Pressure range	n/a
Operating temperature range	-5°C to +40°C
Body material	Thermoplastic
Weight	0.01 kg
Body withstand pressure	1,000
Pressure connection	Ø4 mm spout Pressure or vacuum spout side varies according to contact configuration
Connecting tube reference	2311-08 or 2311-01 to suit Ø4mm
Diaphragm	Neoprene
Mechanical life	1 x 10 ⁶ cycles
Electrical Data	
Contact configuration	SPST N/O or N/C
Contact plating	Gold-or Silver
Contact rating	Max 0.5A 250 VAC
Dry switching current	Min 5 mA 4 VDC
Contact resistance	0.05 Ω



Dimensions

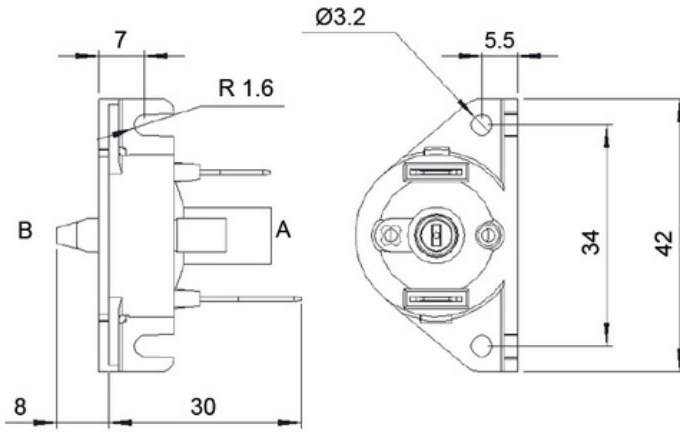



Ordering information

(Please use the characters in the chart below to create your product code)

Sample Code 6753 - A A J G - B 000

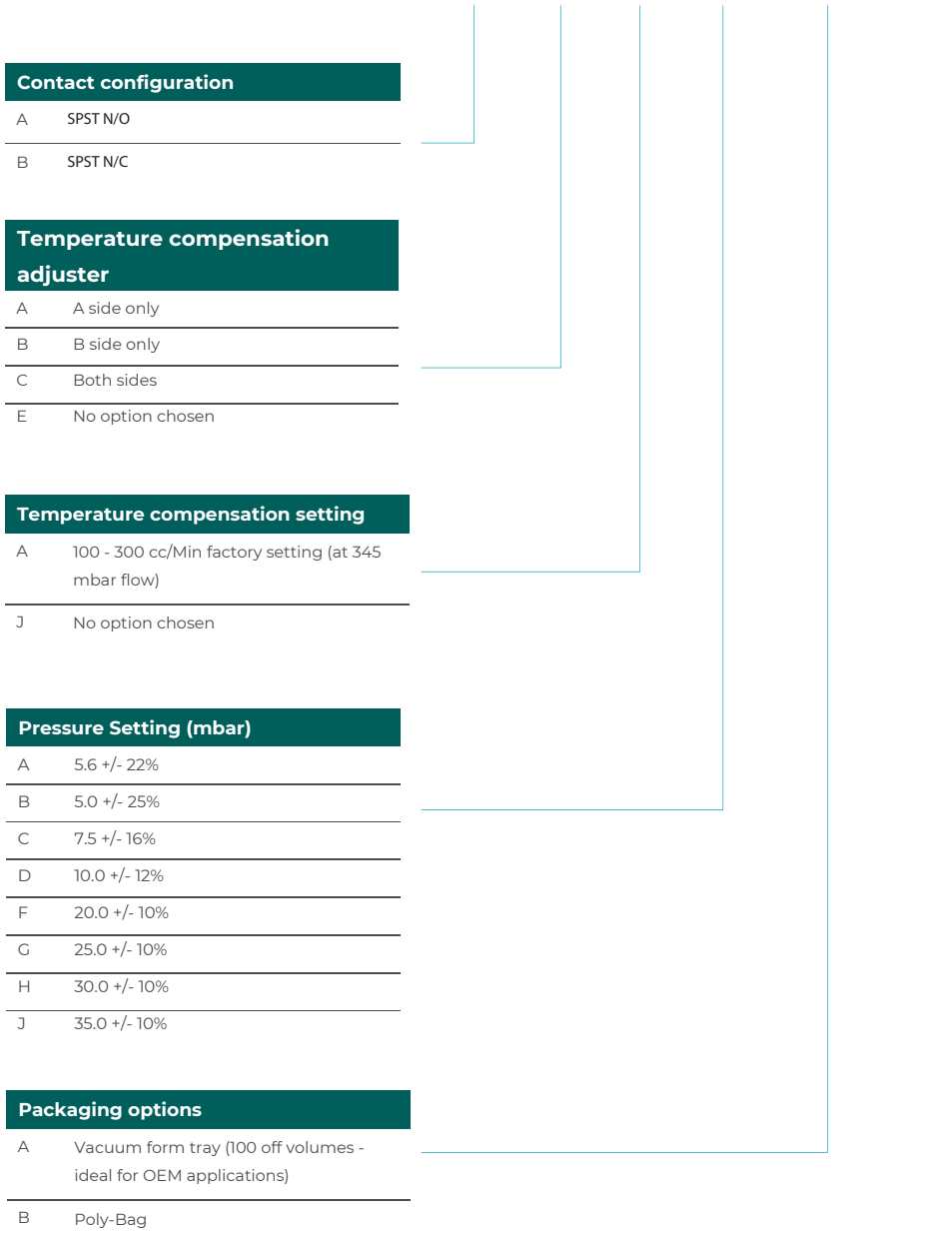

Australian Distributor

K. D. Fisher & Co. Pty Ltd ABN 27 007 879 647
 Head office 18 Benjamin Street St Marys SA
 5042 T +61 8 8277 3288 T 1300 533 474
 E kdf@kdfisher.com.au kdfisher.com.au

If you require a customized solution for your program contact our sales team.